

**Septic Installers' Local Distributor for Monarch Products Co. Inc.
Precast Concrete Products**

Pumps

TANK & PUMPS:

| | |
|-------------|--|
| P-1 | 300 Gal. for Pressure Dosing |
| P-2 | 500 Gal. for Pressure Dosing |
| PT-750R | 750 Gal. |
| ST10-2PTHA | 1,000 Gal. Rectangular |
| P-10 | Duplex Station w/ Pumps Free-Standing |
| P-11 | Duplex Grinder Station w/ Pumps on Rail System |
| P-12 1 of 2 | WET WELL & VALVE VAULT |
| P-12 2of 2 | WET WELL & VALVE VAULT |



CHESAPEAKE BAY SEPTIC TANK, LLC

Septic Installers' Local Distributor for Monarch Products Co. Inc.
Precast Concrete Products

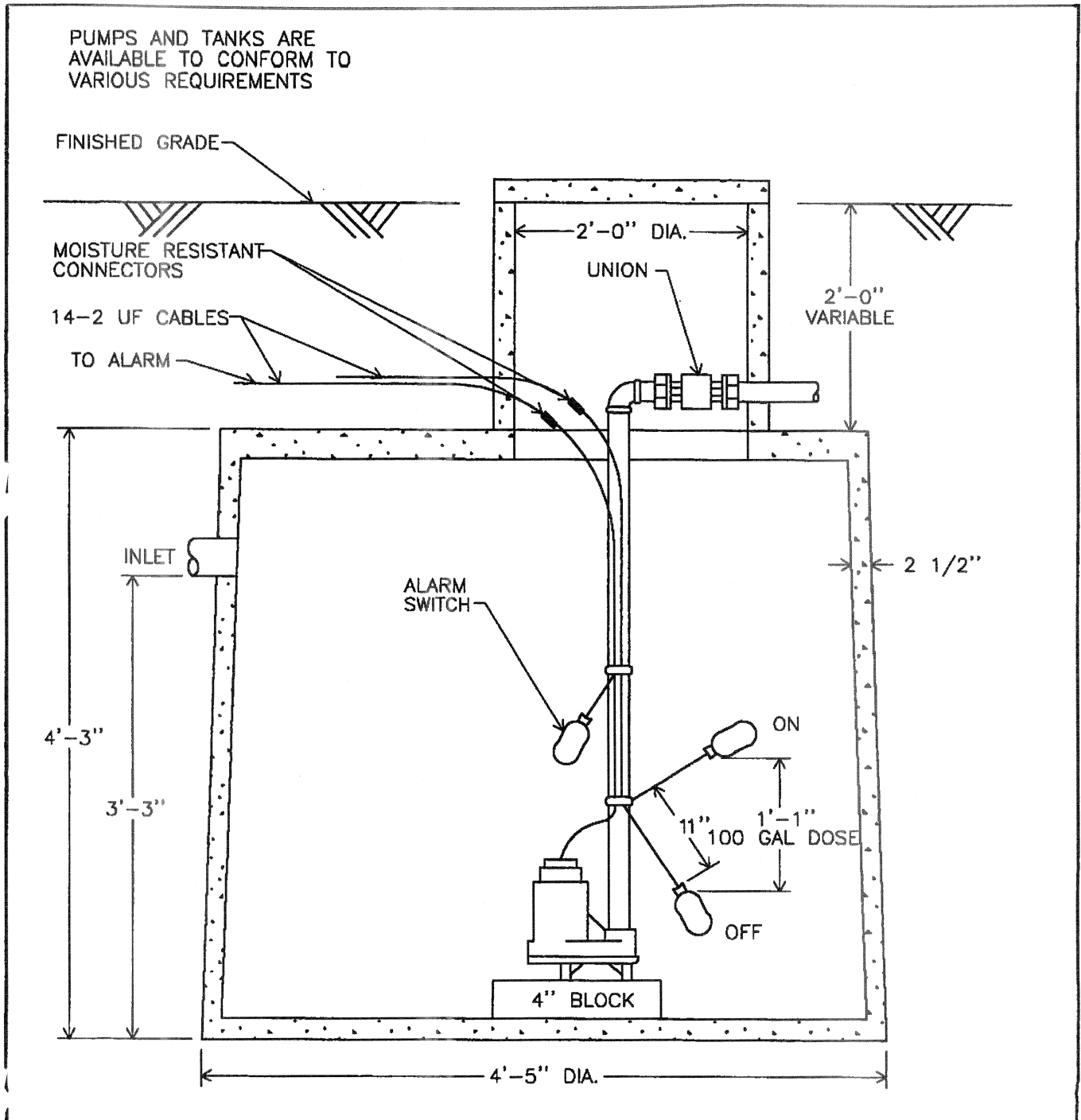

300 GALLON PUMP TANK & PUMP
FOR PRESSURE DOSING

DWG. P-1



CHESAPEAKE BAY SEPTIC TANK, LLC

Septic Installers' Local Distributor for Monarch Products Co. Inc.
Precast Concrete Products

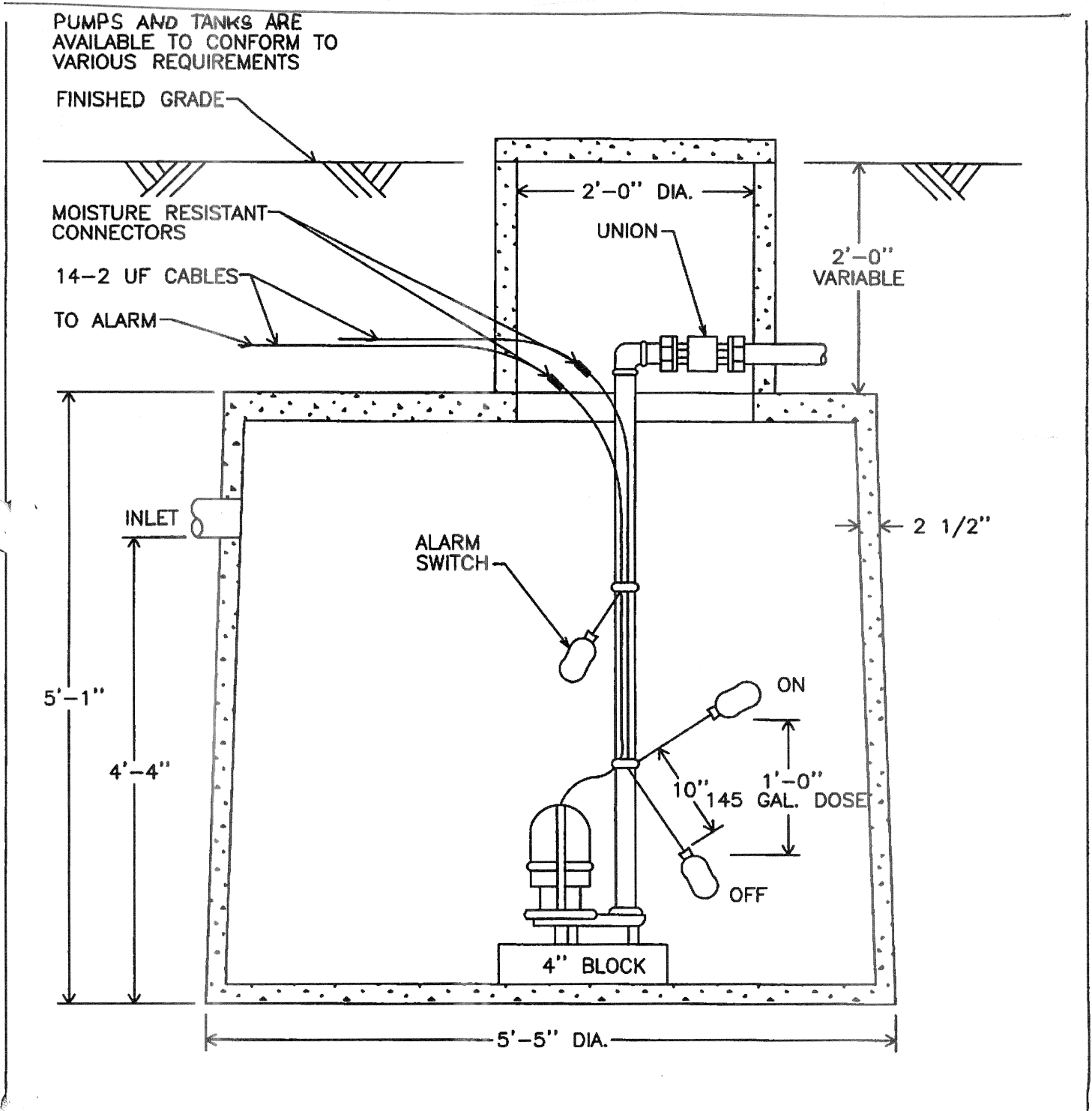

500 GALLON PUMP TANK & PUMP
FOR PRESSURE DOSING

DWG. P-2



CHESAPEAKE BAY SEPTIC TANK, LLC

Septic Installers' Local Distributor for Monarch Products Co. Inc.
Precast Concrete Products

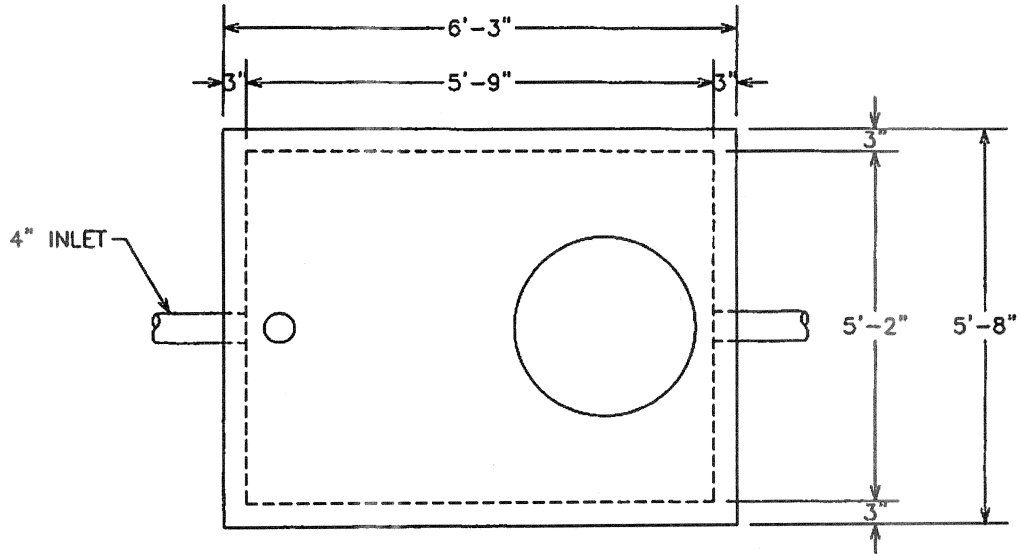

—PLAN—

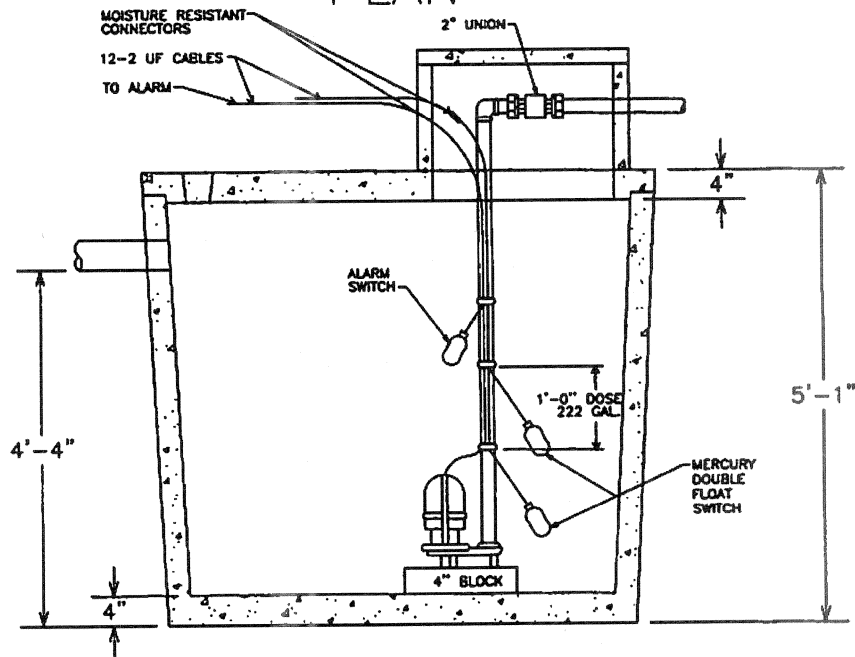

—SECTION—

750 GALLON PUMP TANK
WITH PUMP

PT-750R



CHESAPEAKE BAY SEPTIC TANK, LLC

Septic Installers' Local Distributor for Monarch Products Co. Inc.
Precast Concrete Products

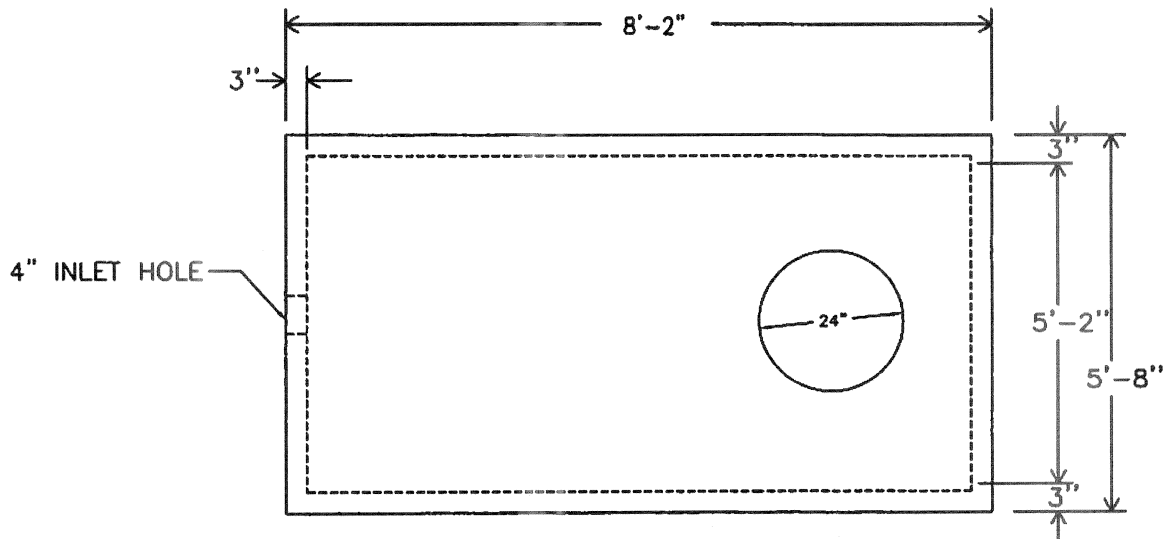

-PLAN-

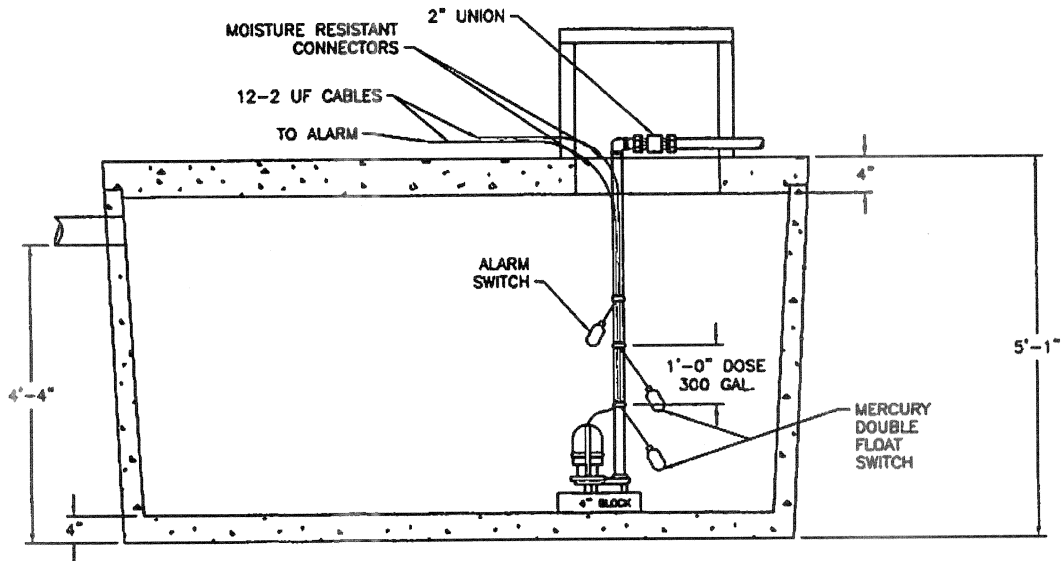

1000 GALLON
RECTANGULAR PUMP TANK

DWG. ST10-2PTHA



CHESAPEAKE BAY SEPTIC TANK, LLC

Septic Installers' Local Distributor for Monarch Products Co. Inc.
Precast Concrete Products

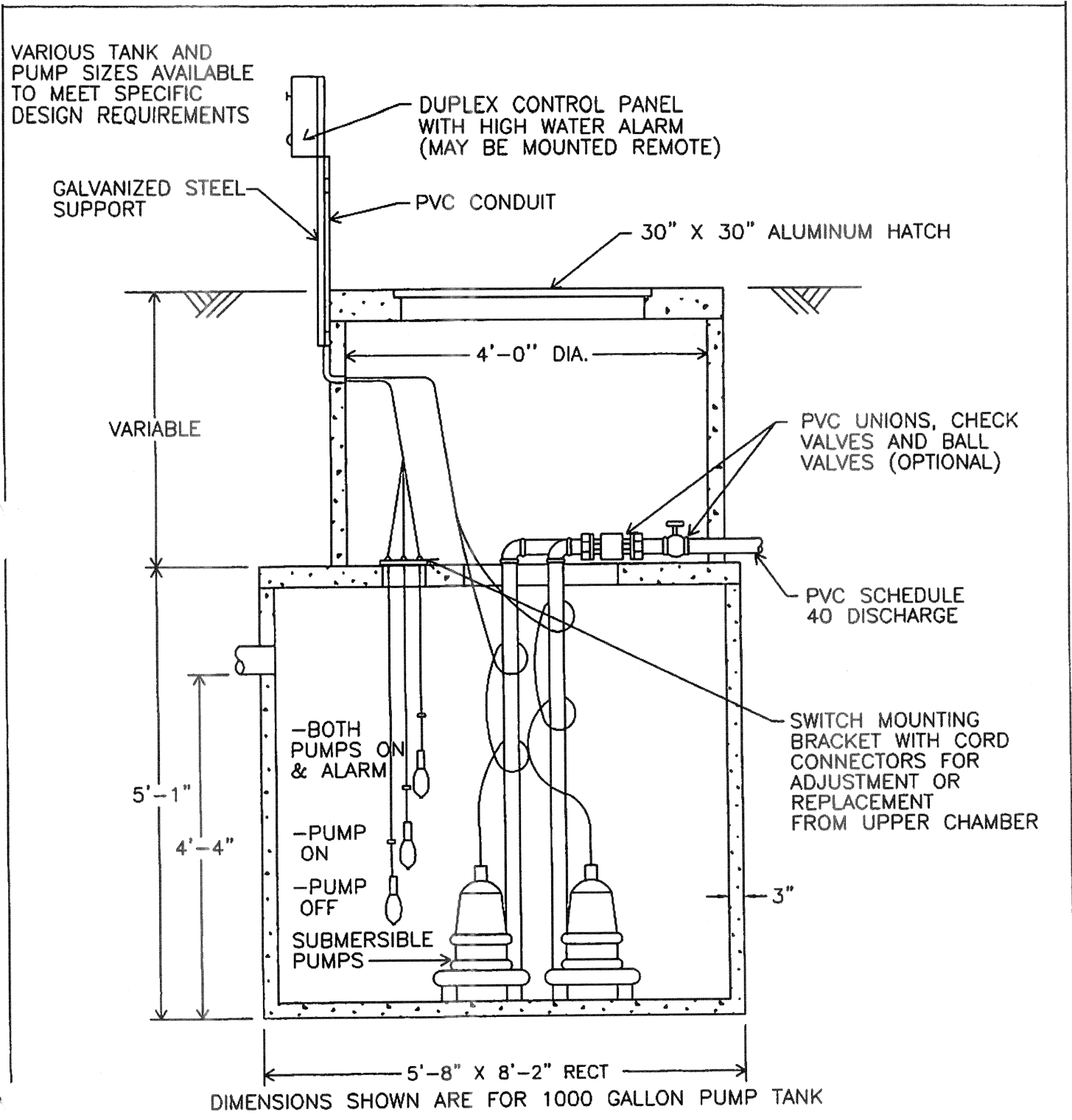

DUPLEX PUMP STATION
WITH PUMPS FREE STANDING

DWG. P-10



CHESAPEAKE BAY SEPTIC TANK, LLC

Septic Installers' Local Distributor for Monarch Products Co. Inc.
Precast Concrete Products

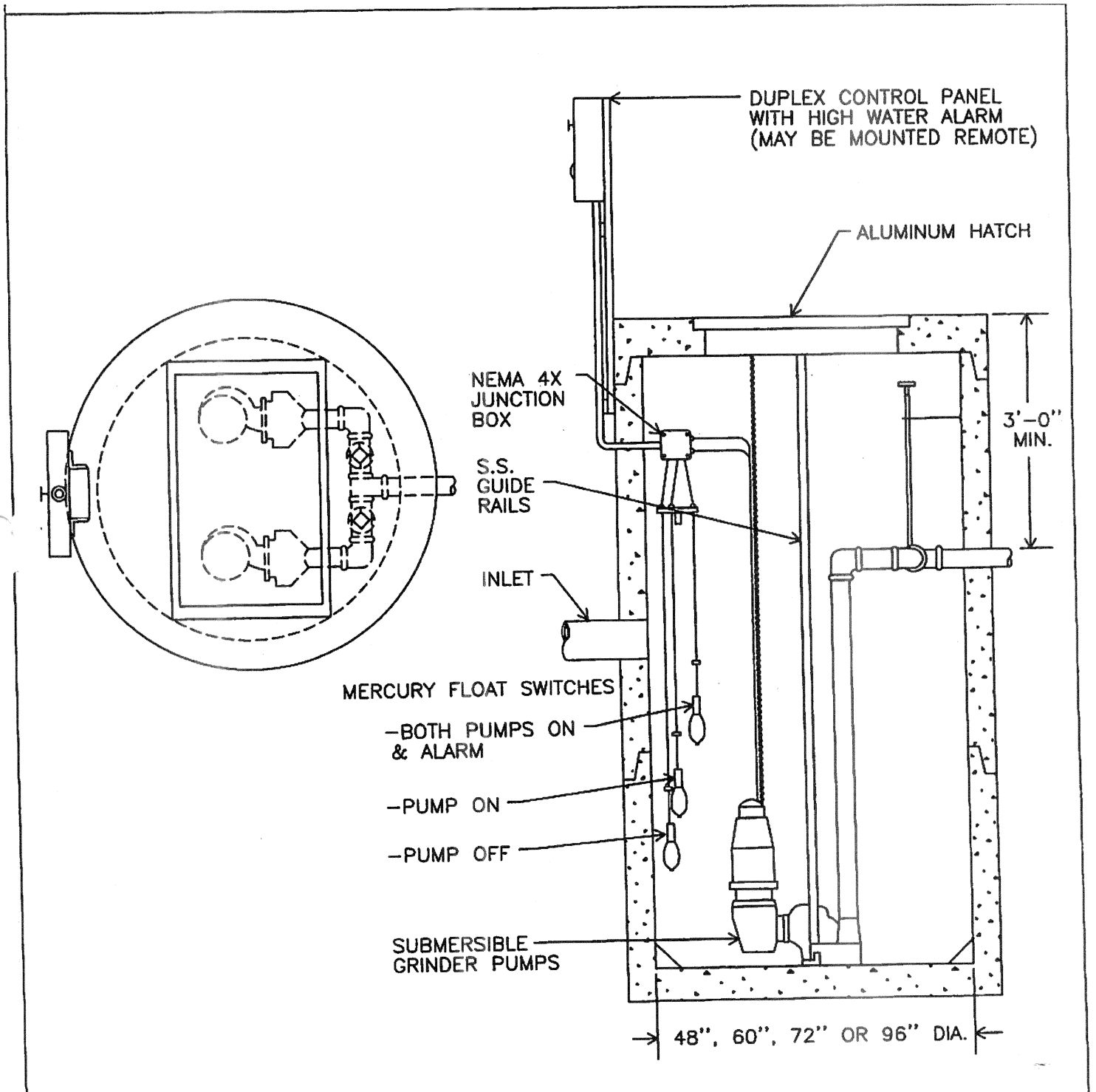

DUPLEX GRINDER PUMP STATION WITH PUMPS ON RAIL SYSTEM

DWG. P-11



CHESAPEAKE BAY SEPTIC TANK, LLC

Septic Installers' Local Distributor for Monarch Products Co. Inc.
Precast Concrete Products

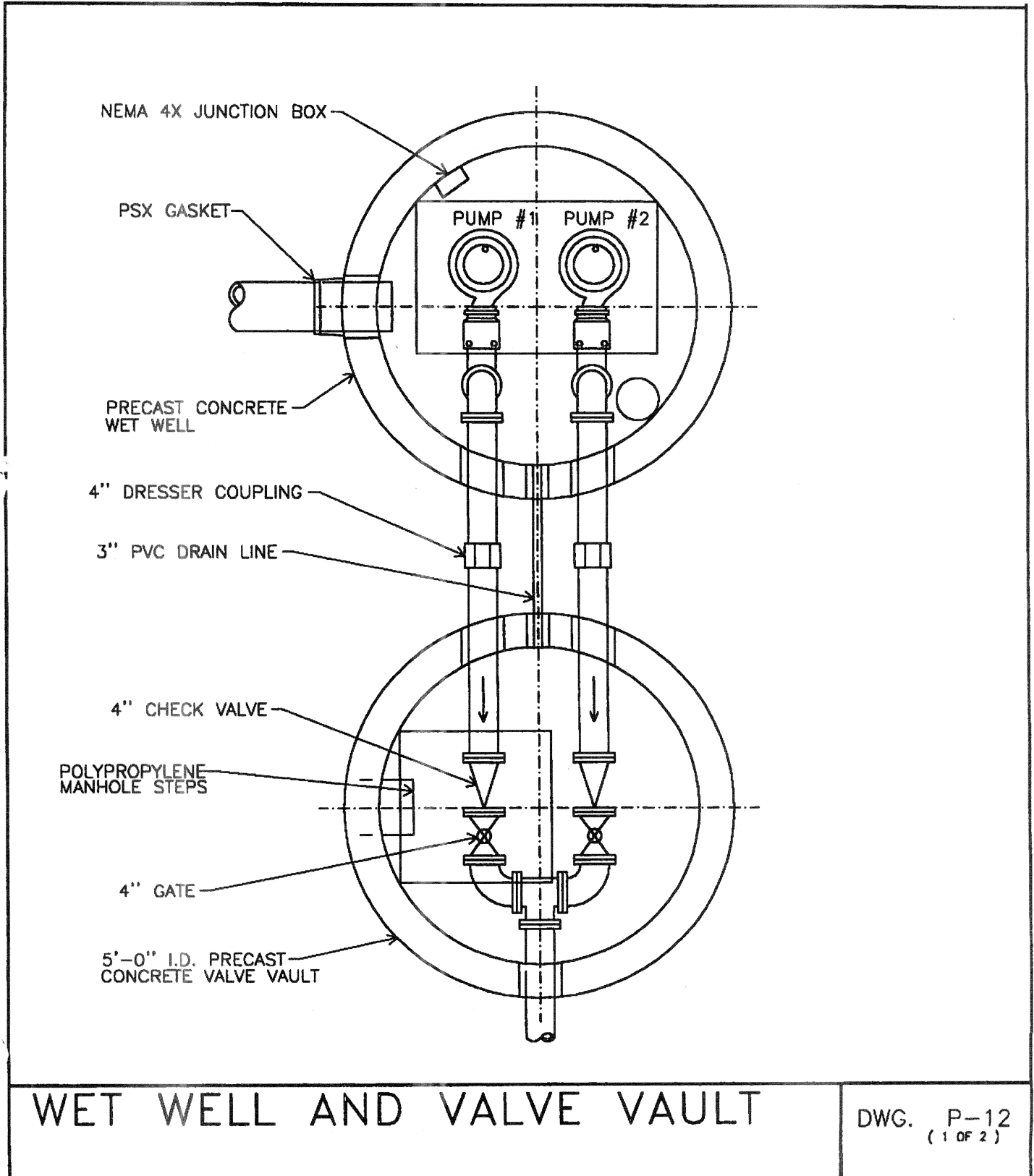



CHESAPEAKE BAY SEPTIC TANK, LLC

Septic Installers' Local Distributor for Monarch Products Co. Inc.
Precast Concrete Products

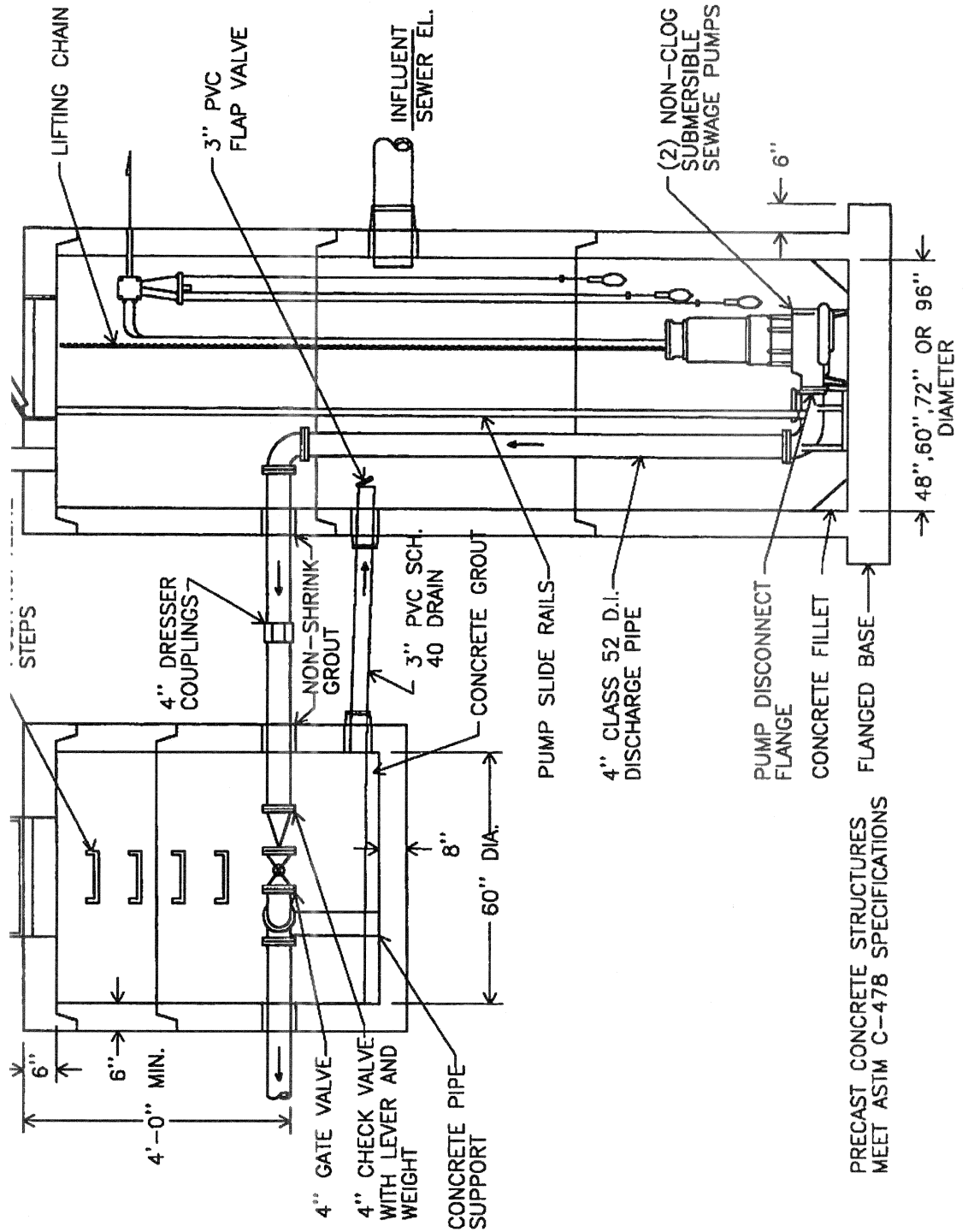

WET WELL AND VALVE VAULT

DWG. P-12
(2 OF 2)